

## Copper Tube, Fittings, Fixtures and Accessories

### Seamless Copper Tube

#### Classification

- BS EN 13348, BS EN 1057 and BS 2871 for tubing

#### Services

- Oxygen
- Nitrous Oxide
- 50% Oxygen / 50% Nitrous Oxide
- Air 400 kPa (4 bar)
- Air 700 kPa (7 bar)
- Medical Vacuum
- Nitrogen
- Carbon Dioxide
- Helium
- Xenon
- Specific mixtures of the above gases
- AGSS

#### Applications for BS EN 13348:2001

- Specifically designed for the medical gas market, recognising the specialist requirements of the industry
- As standard supplied in 60 m bundles, 6 m long and individually capped
- BS EN 13348:2001 supersedes standards such as BS EN 1057 and BS 2871 Part 1 Table X quoted in HTM 2022 and NHS engineering specification C11
- BS EN 1057 is still available for sale

#### Specific Benefits of using BS EN 13348:2001

- Tighter limits on cleanliness determination
- Improved identification to avoid confusion with similar sizes of water service tube

#### Manufacturing Standard

- BS EN 13348:2001
- Unified wall thickness

#### Chemical composition

- CU.DHP to 1190-1
- CW024A to EN1412

#### Temper

- 12 mm to 54 mm - Half hard (Designated R250)
- 76 mm to 108 mm - Hard (Designated R290)

#### Cleanliness

- Maximum total Carbon content 0.20 mg/dm<sup>2</sup>

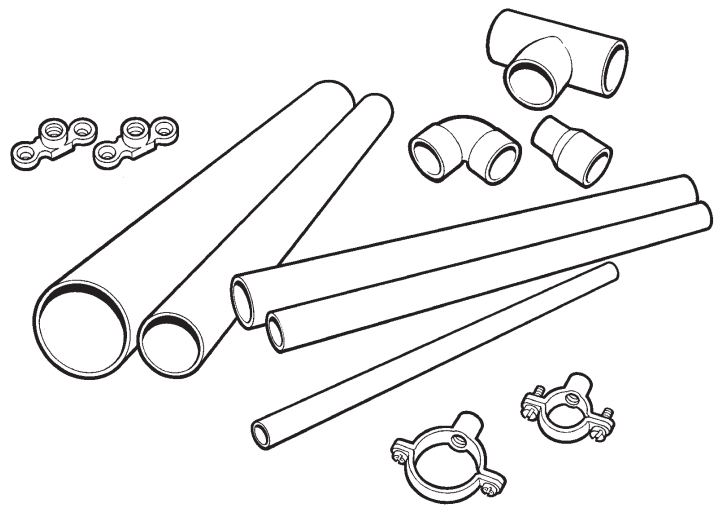

#### Specification

Size	Thickness	Length	Tubes per bundle
12 mm	1.0 mm	6 m	60 m
15 mm	1.0 mm	6 m	60 m
22 mm	1.0 mm	6 m	60 m
28 mm	1.0 mm	6 m	60 m
35 mm	1.2 mm	6 m	6 m
42 mm	1.2 mm	6 m	6 m
54 mm	1.2 mm	6 m	6 m
76 mm	1.5 mm (min)	6 m	6 m
108 mm	1.5 mm (min)	6 m	6 m

Refer to next pages for further information

## Copper Tube, Fittings, Fixtures and Accessories

### Fittings, Fixtures and Accessories

#### Copper Fittings

- Straight couplings
- 90° elbows
- 45° elbows
- Equal tees
- Reducing tees
- Reducing couplings
- Insert reducers
- Tube end caps

#### Copper Fittings Standards

- BS 6017, Non arsenical copper
- BS 864, end feed capillary
- Individually bagged and marked degreased for O<sub>2</sub> use, as per 13.16 in HTM 2022

#### Silver Solder (for Site Installations)

- Type of Product: Silver brazing alloy
- Composition: 6% Silver  
87% Copper  
7% Phosphorous
- Melting Range: 645 to 720°C
- DIN Standard: DIN 8513 : L-Ag6P
- Appearance: Copper coloured metal
- Health Hazard Data: TLV Odour threshold
- Silver: 0.1 mg/m<sup>3</sup> as fume
- Copper: 0.2 mg/m<sup>3</sup> as fume
- Phosphorous: 1 mg/m<sup>3</sup> as phosphoric acid

For in-house manufacturing purposes Penlon uses a higher content of silver for soldering processes (approximately 55%). This is available on request.

#### Pipework Support Systems

- Copper tube wall or ceiling fixing components
- Brass single munsen rings
- Brass double munsen rings
- Brass hospital brackets
- Threaded studding
- Screws and anchors

#### Gas Tape

- 150 mm wide x 33 m long tape available for:
  - Oxygen
  - Nitrous Oxide
  - 50% Oxygen / 50% Nitrous Oxide
  - Air 400 kPa (4 bar)
  - Air 700 kPa (7 bar)
  - Medical Vacuum
  - AGSS
  - Exhaust
- 50 mm x 33 m directional arrow tape
- 50 mm x 33 m Industrial gases, please contact the sales department for further information